



Optional side edge module



Belt Grinding Machine for base tuning SN 350 Profi

Highly qualified, profitable, and extremely stable. Developed especially for the preparation of downhill skis and boards, the SN 350 Profi is an all-round machine. Through continuous development and additional options, the SN 350 Profi is an absolute all-rounder, and has an absolutely unrivaled cost-performance ratio. The board grinding machine is especially equipped with a 350 mm wide, high quality belt.

FEATURES

- > Flexible through movable version with clamped brakes
- > Easy and convenient belt replacement with mechanical belt regulation
- > Conical shape of the contact wheel for precise hold and highest accuracy
- > Double bearing motor shaft
- > Water tank, with fill indicator and cleaning tube
- > Filter drawer for fast removal of grinding residues

OPTIONS

- > Feed unit with mechanical lift-off device
- > Side-edge grinding device, including double support roller with water cooling system and separate drive motor; angle adjustment device from 85° to 90°
- > Edge sharpening device for side edge grinding
- > Snowboard binding cassettes out of aluminium or carbon for plates bindings

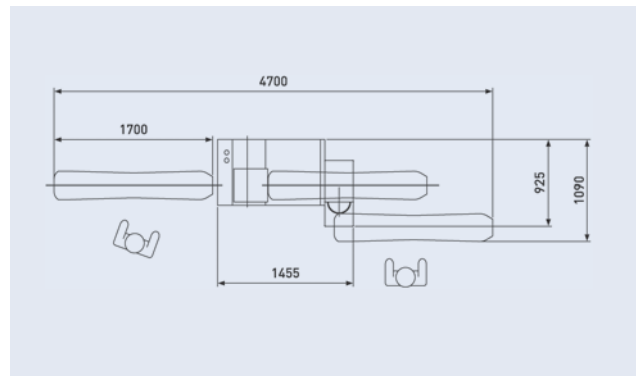

BENEFITS FOR USERS

- > Intuitive, fast and convenient working steps
- > High profitability and a rapid payback period through shortened service work times
- > Low personnel and consumable costs
- > Ensure proper performance for all snow and weather conditions
- > "Made in Germany" machine quality for subsequent decades

BENEFITS FOR CUSTOMERS

- > Material saving grinding increases maintenance and value of the equipment
- > Ensures excellent turning and gliding for relaxed cruising and carving
- > No braking action through base damages
- > The side- edge unit (module "K") offers any customer a secure edge grip, for highest performance and safety on all slope conditions
- > Precise adaptation of equipment to any snow and climatic conditions, for sheer enjoyment

TECHNICAL DATA SN 350 PROFİ

Dimensions without side edge	1150 x 750 x 915
with side edge (L x W x H) in mm	1400 x 1050 x 915
Gewicht without side edge	280
with side edge in kg	330
Connecting voltage	380–415 V, 50 Hz., 3 PH/N/PE
Connecting plug	CEE 16A 5-pol.
Engine speed 1/min	470/960
Connecting power in kW	3,7
Collant tank approx. in l	55
Sanding belt in mm	350 x 2000
Edge tuning belt in mm	20 x 1200
Grinding pressure feed in kg	5–35

ACCESSORIES AND CONSUMABLES SN 350 PROFİ

Description	Article number	Page
Corundum grinding stone	750250	33
Binding cassettes		34
For downhill skis, aluminium	1026649	
For children's skis, aluminium	1027477	
For nordic skis, aluminium	750113	
Sanding Belt		36
Grain 80, 350 x 2000 mm	400729	
Grain 100, 350 x 2000 mm	400730	
Grain 120, 350 x 2000 mm	400985	
Edge tuning belts		39
Grain 80, 20 x 1200 mm	400476	
Grain 100, 20 x 1200 mm	400477	
Grain 120, 20 x 1200 mm	400586	
Tuning belt cork 350 x 2000 mm	401072	36
Polishing belt scotch 350 x 2000 mm	400982	36
Filter socket white	1029066	33
One-hand grease gun	750289	33
Grease cartridge	100067	33