

Machine operation
through touch panelExact stone structure
grinding over
the entire lengthResidue-free grinding
fluid through
filter socket system

Premium base tuning

PROFI S150, PROFI S200 and PROFI S350

With a footprint under 1 m², the new PROFI S150 is the ideal stone machine, ranging from a carving ski to a race-skating-ski for perfect service. All alpine and nordic types will be serviced perfectly by PROFI S200 and PROFI S350 for a variety of snow conditions. The new Reichmann PROFI S series enable optimum turn and glide features for all winter sports fans. Each machine is fitted with a 150 mm, 200 mm or 350 mm wide, high-grade stone, and the future-proof "Profi Structure Package" (PSP) module. Its structure flexibility allows each machine the ability to offer your customer unlimited enjoyment for years to come. Proven "Made in Germany" workmanship, combined with convenient and intuitive handling, provides unique Reichmann base tuning quality. With our premium base tuning machines the right decision can be made for the service future.

BENEFITS FOR USER

- > Bigger user-friendly touch panel for fast and easy control
- > Fast and flexible service ensures excellent customer satisfaction
- > High level customer relationships through know-how transfer: saved surface structures from Reichmann to the customer
- > High profitability due to low personnel and consumable costs
- > "Made in Germany" machine quality for subsequent decades

BENEFITS FOR CUSTOMERS

- > Protection and maintenance of equipment ensure longevity and value
- > Excellent turning and gliding for relaxed cruising and carving
- > Precise adaptation of equipment to climatic and snow conditions for sheer enjoyment

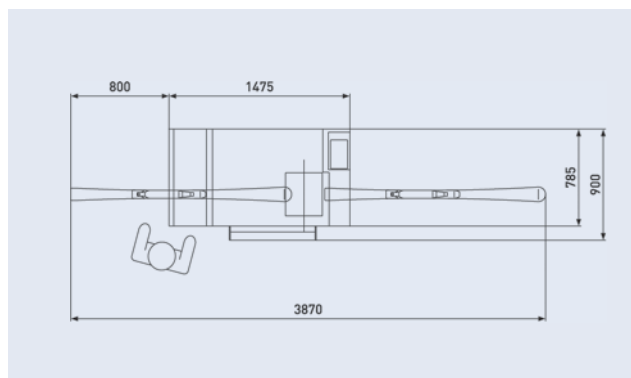

FEATURES PROFI S350

- > Modern touch panel display offers unrivaled handling through an easy in-feed of various structures
- > "Profi Structure Package" (PSP module) enables working with more than 40 base structures, and ensures the development of new structures for the full spectrum of users
- > Variable speed of stone, diamond, and feed allow various structures
- > High pressure flushing system, used for dressing, permits cool grinding units and cleaning stones with an open structure
- > Variable cut and diamond speed, in combination with the pneumatic diamond dressing (integrated compressor), offer highest base structure flexibility
- > Freely selectable dressing cycles and internal diamond cooling greatly extend the service life of the dressing diamond
- > Pneumatically controlled pressure adjustment over entire length of ski and board when grinding, with or without binding cassettes
- > 3-point alignment ensures definite symmetrical structures
- > 2-zone dressing, with two different structures for nordic skis, increase the pace of work (less dressing units) and minimize the abrasion

TECHNICAL DATA PROFI S350

| | |
|-------------------------------------|-----------------------------|
| Dimensions (L x W x H) in mm | 1475 x 785 x 1150 |
| Weight in kg | 500 |
| Connecting voltage | 380–415 V, 3 PH/N/PE, 50 Hz |
| Connecting plug | CEE 16A 5-pol. |
| Engine speed 1/min | stepless |
| Connecting power in kW | 4,35 |
| Collant tank approx. in l | 95 |
| Grinding stone in mm | ø 300 x 350 |
| Dressing speed | stepless adjustable |
| Feed speed | stepless adjustable |
| Grinding pressure feed in kg | 5–50 |

ACCESSORIES AND CONSUMABLES PROFI S350

| Description | Article number | Page |
|---------------------------------|----------------|------|
| Ceramic scraper | 750345 | 33 |
| Binding cassettes | | 34 |
| For downhill skis, aluminium | 1026649 | |
| For children's skis, aluminium | 1027477 | |
| For nordic skis, aluminium | 750113 | |
| Grinding stone | 1025664 | 37 |
| ø 300 x 350 mm, pink | | |
| High Quality Diamond MKD | 1031545 | 34 |
| Emulsion 10 kg | 750331 | 33 |
| Machine cleaning agent | 100349 | 33 |
| Filter socket white | 1029066 | 33 |
| Filter mat | 1031950 | 33 |
| Grease cartridge | 100067 | 33 |
| One-hand grease gun | 750289 | 33 |
| Compressor LFX | | 31 |