

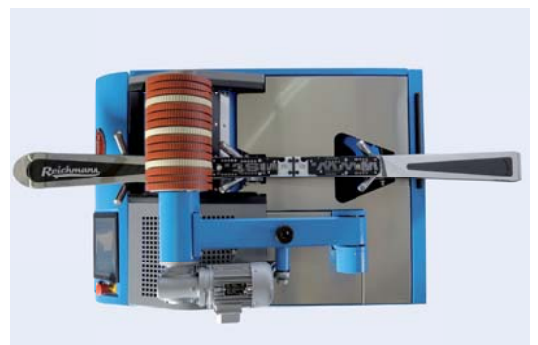

Exact stone structure grinding over the entire length



Tuning miracle with low space requirement

### Premium Base Tuning PROFI S200 and PROFI S350

The PROFI S200 and S350 are the structure miracles among the Reichmann tuning machinery. Both machines are equipped with race structures parameters that have been developed in partnership with race departments of several ski producers. The combination adds up to an effective tuning machine for all clients and rental skis as well, with the additional option to offer professional race service.

#### Reproducible structures

Not only linear structures can be saved on the 150 storage spaces of the computer control thanks to the stepless adjustable velocity of stone, dresser and in-feed. Even "vario" structures can be realized with the machines and recalled by only the push of a button.

The selection of over 70 preset programs takes place confidently and quickly with the color, high resolution 8" touch display with preview function. Additional to the standard functions the PROFI S200 and S350 offer due to the 3-point-centering definite symmetric structures. The pneumatic in-feed of the dresser enables various depths of structures. Due to the "servo-assisted" pneumatic lifting device a balance of grinding with binding bridges can compensate pressure for different widths of skis and boards (PROFI S350). The automatic in-feed offers a smooth transport of ski or board on the stone.

#### For nordic ski and board experts

The PROFI S200 is perfectly suited for nordic and alpine skis with its 200mm stone. The stone can be split into a pre-grind and finish grind structures for nordic skis. This splitting of the stone saves time, and money on stones and dressing diamonds. The PROFI S350 has been developed specifically for alpine skis and snowboards, due to its 350 mm wide, universal stone for clear and fine structures. The PROFI S350 can also utilize the split stone for pre and finish grinding for alpine skis. The

separable feed wheel can balance the pressure distribution for convex and/or concave board shapes.

#### Cleaning

Both stone machines can be cleaned easily due to the 7° sloped tank for a complete accumulation of grinding material at the end of the tank. The special filter system shows the state of the water/emulsion level in the tank, visible from outside, and allows a fast and easy change.

#### A good investment for the future

The PROFI S200 and PROFI S350 will allow you to service a wider range of skier abilities, while doing this at a quicker rate. You will be able to service more skis in less time, all while giving your customers superior quality. The PROFI S200 and S350 require less spare parts and service due to its "Made in Germany" quality.

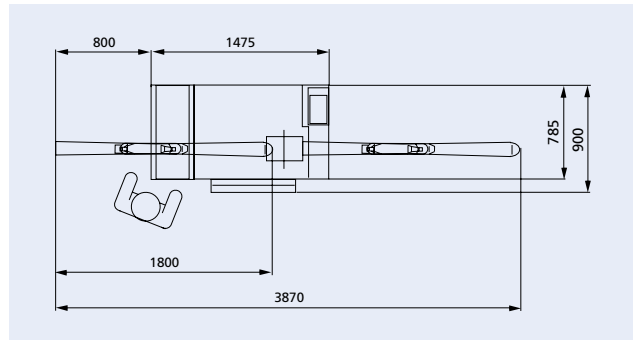

Layout PROFI S200

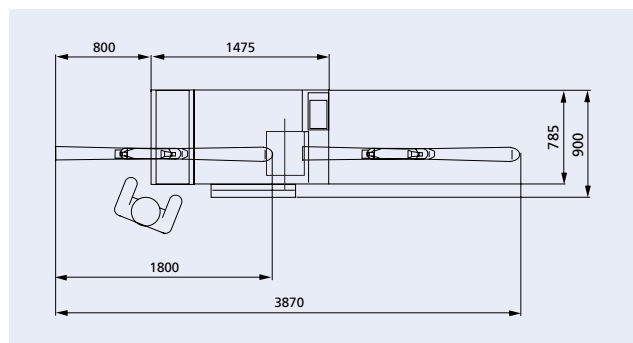

Layout PROFI S350

TECHNICAL DATA PROFI S200

Dimensions (L x W x H) in mm	1475 x 900 x 1150
Weight in kg	450
Connecting voltage	400 V, 3 PH/N/PE, 50 Hz
Connecting plug	CEE 16A 5-pol.
Engine speed 1/min	stepless adjustable
Connecting power in kW	4,35
Coolant tank approx. in l	100
Grinding stone in mm	Ø 300 x 200
Dressing speed	stepless adjustable
Feed speed	stepless adjustable
Grinding pressure feed in kg	5 - 50

TECHNICAL DATA PROFI S350

Dimensions (L x W x H) in mm	1475 x 900 x 1150
Weight in kg	500
Connecting voltage	400 V, 3 PH/N/PE, 50 Hz
Connecting plug	CEE 16A 5-pol.
Engine speed 1/min	stepless adjustable
Connecting power in kW	4,35
Coolant tank approx. in l	100
Grinding stone in mm	Ø 300 x 350
Dressing speed	stepless adjustable
Feed speed	stepless adjustable
Grinding pressure feed in kg	5 - 50

ACCESSORIES PROFI S200/S350

Description	Article number	Page
<b>Ceramic scraper</b>	750345	26
<b>Binding bridge</b>		27
For downhill, aluminium	1026649	
For children ski, aluminium	1027477	
For Nordic, aluminium	1026244	
For downhill, carbon	1031953	
For Nordic, carbon	1031954	
<b>Grinding stone Ø 300 x 200 mm; S200</b>	1031973	28
<b>Structure grinding stone Ø 300 x 200 mm; 1036075</b>		28
PROFI S200		
<b>HQ Dresser PROFI S200</b>	1031545	28
<b>Grinding stone Ø 300 x 350 mm; S350</b>	1025664	28
<b>HQ Dresser PROFI S350</b>	1025477	28
<b>Emulsion</b>	750331	26
<b>Filter socket</b>	1029066	26
<b>Machine cleaner</b>	100349	26
<b>Micro filter mat</b>	1031950	26
<b>Compressor LFX</b>	1014811	25
<b>Grease cartridge</b>	100067	26
<b>One-hand grease gun</b>	750289	26