



Reichmann High-Quality-Tuning DTS-U Pro

Four perfectly tuned edges in just one quick, simple step, to provide unlimited enjoyment and safety for any customer. The innovative arrangement of the tuning disc enables simultaneous treatment of base and side edges. Both side edges can be by-passed at the discs wheels, while the base edges are polished from below by the circumferential polishing wheel. The Reichmann Edge-Tuning-Concept HQT (High-Quality-Tuning) is a perfect addition to all base tuning machines. The combination of these machines in any service work shop will provide a lean servicing process along with the achievement of excellent profitability and quality.

FEATURES

- > Optimum matching of disc to side edges and circumferential polishing wheel for the base edges guarantee precise edge geometry across the length of any ski or snowboard
- > Single operation ski and snowboard service enables a less than 30 second tuning time
- > Optimum combination of the disc and circumferential polishing wheel, with exact adjustable grinding angles, guarantees planed, burr-free edges, as well as precise edge geometry over the complete ski and board length
- > Automatic adjustment of grinding pressure guarantees a constant side edge cut
- > Unique HQT (High-Quality-Tuning) of base edge ensures outstanding driving features; edges will not be rounded and greater duration of edge sharpness is guaranteed
- > Modern touch-screen provides convenient control and fast adjustment of the tuning parameters, thereby offering an unrivaled ease-of-use
- > Automatic dressing replicates same excellent mirror finish on both side edges

Innovative arrangement
of grinding discs sets
new quality standards

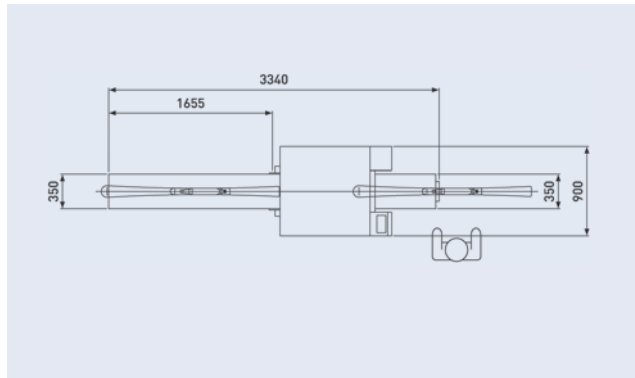

BENEFITS FOR USERS

- > Four edges, one working process
- > Faster, automatic working process in only one step
- > Constant grinding results
- > Reduced material, time, and cost efforts
- > "Made in Germany" machine quality for subsequent decades
- > Excellent service allows for increased rental and improved customer loyalty

BENEFITS FOR CUSTOMERS

- > Perfectly serviced edges guarantee optimized turning performance and maximum edge-grip for a better stability and enhanced security
- > Long-lasting edge sharpness provides long-lasting enjoyment
- > Best grip on all snow conditions, particularly artificial snow, enhances safety and increases skier and rider confidence

TECHNICAL DATA DTS-U PRO

Dimensions (L x W x H) in mm	1450 x 900 x 1625
expanded	3350 x 900 x 1625
Weight in kg	490
Connecting voltage	400 V, 3 PH/N/PE, 50 Hz
Connecting plug	CEE 16A 5-pol.
Connecting power in kW	2,5
Engine speed 1/min	1350
Compressed air connection in bar	6
Tuning wheel in mm	2 x ø 250 x 55
Disc wheel side edge in mm	2 x ø 150 x 25
Feed speed	variable

ACCESSORIES AND CONSUMABLES DTS-U PRO

Description	Article number	Page
Corundum grinding stone	750250	33
Binding cassettes		34
For downhill skis, aluminium	1026649	
For children's skis, aluminium	1027477	
Ceramic grinding wheel white ø 150 x 25 mm	1023989	37
Polishing-/Tuning wheel grey ø 250 x 55 mm	1013178	37
Emulsion 10 kg	750331	33
Machine cleaning agent	100349	33
Filter mat	1024839	33
Filter socket white	1029066	33
Filter paper roll	400604	33
Diamond for tuning wheels	401098	34
Grease cartridge	100067	33
One-hand grease gun	750289	33
Compressor LFX		31